

TURBINE METER SERIES

FMT-Lx



The best way to predict the future *is to create it*

Introduction

The FMT-Lx series turbine meters is a robust meter, designed to perform on the highest level of accuracy. The meters comply with all international standards and are approved for custody transfer. The actual flow sensor, an exchangeable cartridge, has a built-in multi stage flow conditioner enabling the meter to be installed without any straight in- and outlet sections. All tested and proved according perturbation test as per international standards.

The cartridge can be pre-calibrated, under both low and high pressure conditions, then exchanged on-site. The cartridge is supported in O-rings and isolated from the body, hence unaffected by any influences of the housing. The short length cartridge enables the use of larger sized cartridges than the size of the meter body. The approved maximum capacities of these kind of meters are extremely high and similar to the capacities of ultrasonic meters.

To reduce transportation cost, optimize the corrosion protection and improve safety in handling, the FMT-Lx series of turbine meters up to 6" (DN150) are also available with low weight aluminum meter bodies.

Principle

The operation of the FMT series of turbine meter is based on the measurement of the velocity of gas. The flowing gas is accelerated and conditioned by the integrated multi stage flow conditioner. The multi stage flow conditioner prepares the gas flow profile by removing undesirable swirl and asymmetry before the gas flows over the freely rotating turbine wheel.

The dynamic forces of the flowing gas cause the rotor to rotate. The turbine wheel is mounted on the main shaft, with high-precision, low-friction ball bearings.

The turbine wheel has helical blades that have a known angle relative to the gas flow. The gas flow drives the turbine wheel at an angular velocity, which is proportional with the gas velocity. Using a gearing mechanism, the rotating turbine wheel drives the mechanical counter.

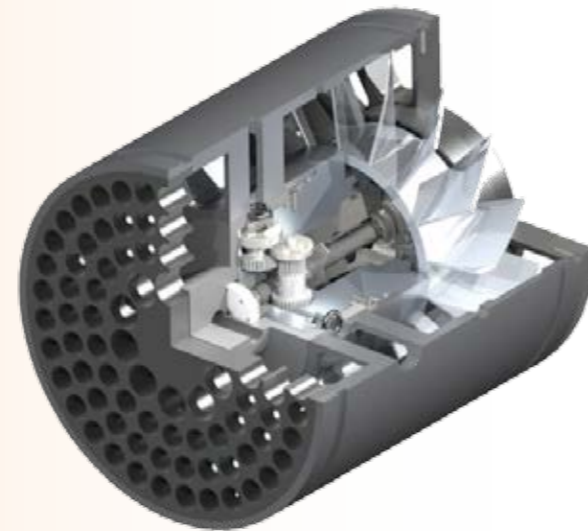

Applications

The standard FMT-Lx turbine meter is suitable for custody transfer gas measurement of all non-corrosive gases such as natural gas, propane, butane, air, nitrogen, hydrogen, etc. for low and high operating pressures. Special constructions can be supplied for use under extreme condition like high temperatures or corrosive gases. The FMT-Lx can be modified to perform as a master meter or transfer master meter.

Accuracy

Each FMT-Lx turbine gas meter is tested with atmospheric air to traceable calibrated references. The error limits are typical half of those allowed by MID, EN standards or OIML recommendations. For pressures of above 8 bar even narrower limits are available. Optionally, meters can be calibrated with natural gas at pressures up to 100 bar, using test installations traceable to primary standards.

Typical metrological characteristics

Accuracy 0,2 Q_{max} to Q_{max}: ± 1% or better
 Accuracy Q_{min} to 0,2 Q_{max}: ± 2% or better
 Repeatability: better than 0,1%

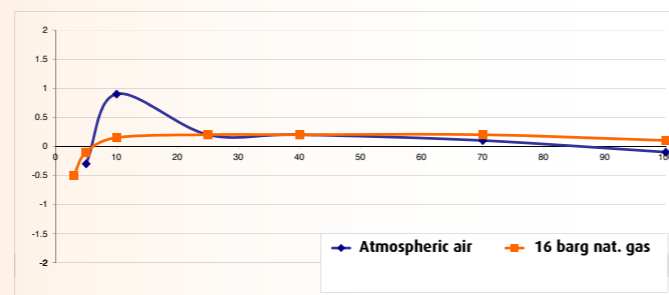

Measuring range

The measuring range of the FMT-Lx turbine meter determined under atmospheric conditions meets with, and generally exceeds, the international standards. At higher operating pressures the measuring range of the turbine meters will increase since the required kinetic energy transfer to the turbine rotor occurs at lower velocities. The measuring range equation may be used to estimate the minimum flow rate of the meter for various operating conditions.

Pressure Loss

The average pressure loss (see tables pages 6-7) of the FMT-Lx turbine meter using atmospheric natural gas with a relative density of 0.6 is measured at one (1) diameter upstream to one (1) diameter downstream of the meter on straight pipe of the same size as the meter. The pressure loss across the FMT-Lx turbine meter for various gases and other operating pressures may be approximated from the pressure loss equation:

$$Q = Q_{min} \sqrt{\frac{P_{atm}}{P} \times \frac{1.29}{\rho}} [m^3/h]$$

ΔP_2 = Pressure drop at P and Q_{max}
 ΔP_1 = Pressure drop at Q_{max} (See tables pages 6 and 7)
 P = Operating pressure of the meter in bar absolute
 P_{atm} = Atmospheric pressure in bar absolute (1.01325 bara)
 Q = Instantaneous flow in m³/h

$$\Delta P_2 = \Delta P_1 \times \frac{d}{0.6} \times \left(\frac{P}{P_{atm}}\right) \times \left(\frac{Q}{Q_{max}}\right)^2 [Pa]$$

Q_{max} = Max. Flow rate in m³/h
 Q_{min} = Min. Flow rate at atmospheric pressure in m³/h
 d = Relative density of the gas (air = 1)
 ρ = Density of the gas at atmospheric pressure



Main Features

- Flow range 3- 40.000 m³/h
- Diameters DN50 - DN600 (2" - 24")
- Pressure rates PN 10 - 100, ANSI 150 - 600
- MID approved
- MID temperature range -25 to +70°C
- Length 1x DN
- Removable meter cartridge
- No straight inlet/outlet sections required
- Oil flushing and lubrication system
- Multipurpose exchangeable index
- Tamper proof IP67 sealed index
- Special meters on request

Installation

The FMT-Lx fulfills all the requirements of the European and International directives. In particular those of the OIML, ISO and EN. With the special integrated flow straightener the FMT-Lx eliminates the effect of severe perturbations on gas measurement. Straight inlet and outlet piping can be 0 X DN. This permits the design of very compact installations without losing accuracy.

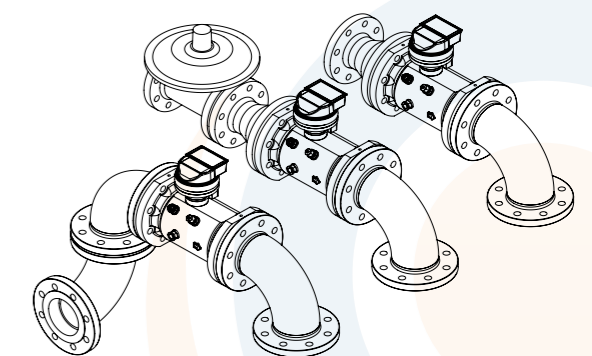

Minimum Installation Configurations

Index

The basic index consists of an UV-resistant polycarbonate cover, glued (IP67) to an aluminum frame. The aluminum frame will give strength to the index and as such sufficient protection against mechanical interference (Tampering). The index can be rotated over 350° for all directions. The index can be equipped with multiple LF switches (Reed or Wiegand principle), "Normally Closed" tamper contacts and encoder technology. The LF pulsers and its driving magnet are shielded to overcome tampering with an externally applied magnetic field. Magnetic fields up to 500 mT will not have an effect on the pulse counting. The index or instrument drive can be equipped with several options making the meter prepared for the future:



Double reed plus normally closed contact:

All basic indexes are equipped with an double reed and a normally closed contact. Reverse Flow Lock: In order to avoid tampering by reverse flow, the index or instrument drive can be equipped with a Reverse Flow Lock.

Wiegand Pulsers:

The Index can be equipped with multiple Wiegand pulsers. The Wiegand pulsers do have significant advantages over the traditionally used Reed contacts. Wiegand sensors do not face "bouncing" problems and the actual live time is not limited as much as the traditional Reed contacts.

Intelligent Index/Encoder:



The index can be equipped with an intelligent encoder. The encoder sends out the total volume with an interval of 400 msec. The encoder uses a standard NAMUR serial data format, and can be modified to special applications on request. The encoder is powered by one AA cell battery guaranteed for 12 years of operation. On request two AA cells can be installed for a guaranteed life time of 20 years. The encoder is equipped with a special Hall sensor to detect and register interferences from external magnets. Several programmable inputs/outputs are available for advanced - anti fraud - functions.

Adjustable with
DIN-3374 sets



Lubrication

The FMT series of turbine meters can be equipped with several types of lubrication systems or with life time lubrication. FMG recommends to use the lubrication system. An integrated splash vane will distribute the oil to all the moving parts and will flush the bearings. The FMT-Lx series incorporates high quality precision bearings. For optimal life times guarantees it is recommended they should be lubricated and clean. Recommendations as to when to lubricate turbine meters varies by product type, operating conditions, customer procedures, and regulatory requirements. Meter performance is optimized by flushing contamination from the bearings and refreshing or adding of oil during operation.



Heavy duty bearings

Since gas pressure causes the main force on the bearings the FMT-Lx series incorporates bearings dedicated to the working pressure. FMT-Lx turbine meters which have a low working pressure are equipped with lighter bearings then the meters which are used at higher working pressures. This way the best measuring ranges and life times can be guaranteed.

Low pressure



High pressure

High Frequency Sensors

FMT-Lx Turbine meters can be equipped with several types of high frequency sensors.

HF main shaft: this high frequency sensor generates two independent phase shifted signals and as such the flow direction can be monitored. The signal generated complies with Namur.

HF turbine wheel: this HF sensor can be used to check the condition of the turbine wheel (missing blades) by comparing the pulses with the HF main shaft.

For both sensors, the electrical separation between the hazardous and non-hazardous areas is accomplished by an intrinsically safe isolation amplifier.

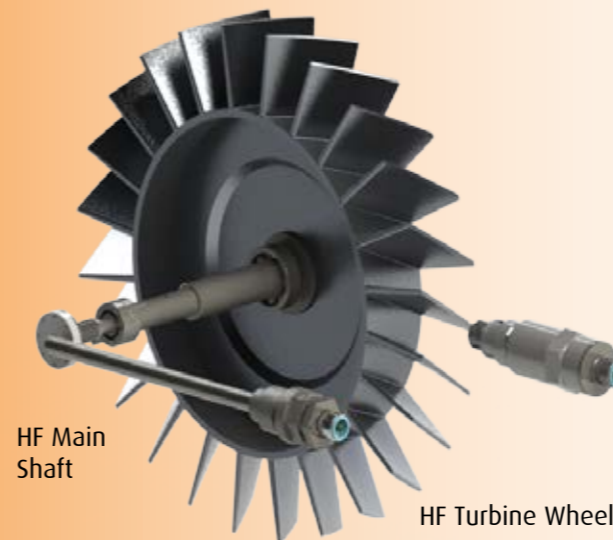

HF Main
Shaft

HF Turbine Wheel

Approved maximum capacities

All metrological characteristics are embedded in the cartridge, making the meter body a non-essential part of the meter. Hence offering new opportunities as using smaller and larger cartridges in respect to the meter body size (DN). Thus allowing a large variety of capacities. Due to the short length of the cartridge, it can be exchanged for a cartridge of higher capacity. For example, a cartridge for a 6 inch meter can be installed in a 4 inch body. The approved maximum capacities of these kind of meters is extremely high and similar to the capacities of ultrasonic meters.



Technical Specification

Metrological approvals:	compliant with the MID 2004/22/EC compliant with OIML R137
ATEX approvals:	sensors compliant with Ex ia IIC T4... T6 Gb (-40°C ≤ Ta +70°C) encoder compliant with Ex ib IIB T3... T6 Gb (-25°C ≤ Ta +55°C)
Flow rates:	3 m ³ /h up to 40.000 m ³ /h
Nominal diameters:	from DN50 to DN600 mm (2" to 24").
Mounting position:	horizontally or vertically
Body	compliant with the Pressure Equipment Directive 97/23/EC
Temperature Range:	ATEX: -25°C to +70°C MID: -25°C to +70°C (lower temperatures on request) PED: -20°C to +70°C (lower temperatures on request)

Materials:

Straightening vane:	aluminum	Shafts:	stainless steel
Turbine wheel:	aluminum	Gears:	delrin
Cartridge	aluminum	Index frame:	aluminum
Bearing block:	stainless steel/aluminum	Index frame:	polycarbonate/ECI
Bearings:	stainless steel		

About us

FLOW METER GROUP B.V. (FMG)

FMG is an engineering/manufacturing company specializing in the development and production of energy and gas measurement systems. Located in the Netherlands, FMG produces a wide range of rotary and turbine gas meters, volume conversion devices, master meters and calibration benches. Unique product features include self diagnosis and tamper prevention. All products and services are certified by the Dutch NMI and comply with the latest EU and/or OIML directives.

Flow Meters

FMG offers a large variety of flow meters ranging from very small (100 dm³/h) up to very large (40.000 m³/h) flow rates and in pressures from atmospheric to 100 bar (1440 psi). All FMG meters comply with international safety and metrological standards. Meters designated for fiscal use are tested, certified and approved by the Netherlands Metrological Institute NMI.

FMG has added extra features to the meters in terms of increased accuracy, protection from manipulation, increased rangeability and superior performance in order to go beyond the minimum requirements of the existing standards.



Positive Displacement Meters

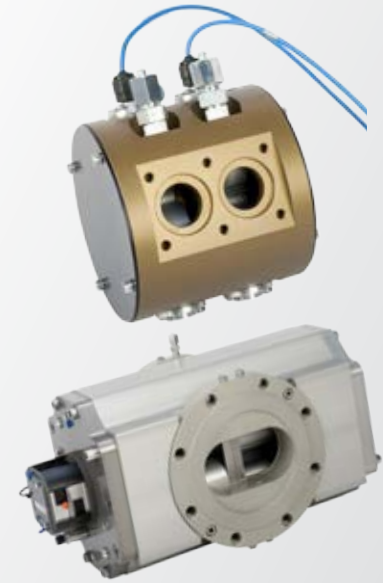

Master Meters



Custody Transfer Short Length Turbine Meters



Flow Computers



Test Benches

Contact



Flow Meter Group B.V.
Meniststraat 5c
7091 ZZ Dinxperlo
The Netherlands

Tel: +31 (0)315 651 556
Fax: +31 (0)315 651 448

E-mail: info@flowmetergroup.com

